

e-ISSN: 2721-303X, p-ISSN: 2721-3021  
Received: 28 August 2021, Revised: 14 September 2021, Publish: 25 September 2021  
DOI: <https://doi.org/10.38035/dijefa.v2i4>  
<https://creativecommons.org/licenses/by/4.0/>



## **Influence Of Net Income And Current Ratio To Cash Dividends In Mining Companies Listed In Indonesia Stock Exchange Period 2012-2016**

**Fakhri Harpin Yulio<sup>1</sup>, Rina Asmeri<sup>2</sup>**

<sup>1)</sup> University of Ekasakti, Padang, Indonesia [fakhriharpiny@gmail.com](mailto:fakhriharpiny@gmail.com)

<sup>2)</sup> University of Ekasakti, Padang, Indonesia [rinaasmeri21@gmail.com](mailto:rinaasmeri21@gmail.com)

**Abstract:** This study aims to determine whether net income and current ratio significantly influence cash dividends in mining companies listed in the Indonesia Stock Exchange period 2012-2016 either partially or simultaneously. The type of data used in this study is quantitative data sourced from the company's financial statements. Data source in this research is secondary data. The population in this study is a manufacturing company coal mining of industrial sub sector listed in the Indonesia Stock Exchange amounted to 24 companies. The sampling technique used purposive sampling technique according to predetermined criteria. Based on predetermined criteria, there are 6 companies. The method of analysis used in this study is multiple linear regression analysis and hypothesis testing using t test and f test. The results of this study indicate that partially net income and current ratio significant effect on cash dividends. Simultaneously net income and current ratio have a significant effect on cash dividends.

**Keywords:** Net Income, Current Ratio, Cash Dividends

### **INTRODUCTION**

Indonesia is one of the largest coal producers in the world. Since 2005, when it surpassed Australian production, Indonesia has been a leading exporter of coal. Since the early 1990s, when the coal mining sector was reopened to foreign investment, Indonesia has experienced an increase in domestic coal production, exports and sales. Indonesia is affected by these external factors because commodity exports (especially for coal and Palm oil) contributes to around 50% of Indonesia's total exports, thus limiting GDP growth in 2009 to 4.6%.

In the second half of 2009 until the beginning of 2011, global coal prices experienced a sharp decline. This decline in global economic activity has reduced coal demand, resulting in a sharp decline in coal prices from early 2011 to mid 2016 in Indonesia Investments (2017). In the 2016 quarter, coal prices rose again to reach 100 US\$/ton and it is projected that in 2017, coal prices will stabilize at 80 US\$/ton, so that the prospect of the coal industry

is now considered to be better than other commodities, with increased consumption. domestically, with the government's plan to build power plants using coal.

Several investors in investing their funds in the capital market aim to be able to obtain dividends or to obtain capital gains. Dividends have a lower risk than capital gains. Shareholders can receive two types of dividends, namely cash and non-cash dividends.

The factors that influence the distribution of cash dividends are liquidity position, company debt repayment, expansion rate, company access to capital markets, shareholder position, earnings prediction, ownership control, and inflation (Erawati and Sisdayani in Herlas Tia Dekayani, 2014). Another factor that affects cash dividends is net income, profit has a positive relationship with cash dividends, this can be seen where generally companies will increase dividends if there is an increase in profits (Muhammad Ridha Ramli and Muhammad Arfan, 2011).

From the various research results that have been carried out, it shows different results between one researcher and another regarding the factors that affect cash dividends, so further research is needed.

Mining companies are required to carry out risk management to avoid the negative impacts of external conditions and changes that occur. Banking companies as part of the mining business that provide funding need to be selective in channeling their funds, considering that in previous years, banking performance in the form of Non-Performance Loans (NPLs) was still not good. This is also supported by companies engaged in the mining sector also register on the Jakarta Stock Exchange (JSX) to obtain funding and demand clean and professional mine governance.

## LITERATURE REVIEW

### Net Profit

According to Hery (2012) profit before income tax is deducted by income tax will get a net profit or loss. This net profit or loss provides users of financial statements with a summary measure of the company's overall performance during the current period (which includes both primary and secondary activities) and after calculating the amount of income tax.

The formula for finding net income is as follows:

$$\text{Net profit} = \text{Profit before tax} - \text{Income tax}$$

Source, Hery (2012)

### Current Ratio

According to Kasmir (2016), the current ratio is a ratio to measure the company's ability to pay short-term obligations or debts that are due immediately when billed in their entirety. In practice, it is often used that the current ratio is with a standard of 200% (2:1) which is sometimes considered good or satisfactory for a company. This means that with the results of such a ratio, the company is already at a safe point in the short term.

The formula for finding the current ratio is as follows:

$$\text{Current Ratio} = \frac{\text{Aktiva Lancar (Current Assets)}}{\text{Utang Lancar (Current Liabilities)}}$$

Source, Cashmere (2016)

## **Dividend**

According to Dwi Martani, et al (2015) dividends are part of the profits distributed to shareholders. When a company declares a dividend, it must meet legal requirements and have a number of assets to distribute.

### **Types of Dividends**

#### **1. Cash Dividend**

According to Dwi Martani, et al (2015) dividends can be issued in various forms. The most common form is cash dividend, in which the company distributes cash to shareholders in a certain proportion, referring to the dividend payout ratio, of net income.

#### **2. Non-Cash Dividend**

According to Ahmad Sandi and Nur Fadjrih Asyik in Herlas Tia Dekayani (2014) non-cash dividends are dividends paid in the form of shares with a certain proportion. According to Dwi Martani, et al (2015) other forms of dividends apart from cash dividends include the following:

##### **1. Stock Dividend**

Distribution of shares of the company concerned on a pro-rata basis to its shareholders. In Indonesia, the shares distributed as dividends are called bonus shares. Thus, shareholders have more shares after receiving stock dividends.

##### **2. Property Dividend**

Property dividend is a dividend distribution in the form of company assets. If the company wants to distribute this type of dividend, the company must assess the fair value of the asset and recognize any gain or loss as the difference between the fair value of the asset and the book value of the asset on the declaration date.

##### **3. Dividend Script**

Is a promissory note that states a sign of willingness to pay a certain amount of cash to shareholders as dividends. The dividend distribution policy in the form of a scrip dividend is carried out by the company if at the time of making a decision on dividends the company does not have sufficient cash to pay in the form of cash dividends.

##### **4. Liquidation Dividend**

Dividends that are based on other than retained earnings are referred to as liquidating dividends because they are not based on profits and reduce the total share capital of the company. If the company issues dividends and the retained earnings cannot meet the dividend amount, the dividend amount is taken from the share capital. Therefore, liquidating dividends will reduce the amount of the company's share capital.

### **Distribution Procedure Dividend**

According to Dwi Martani, et al (2015) in the distribution of cash dividends, there are four relevant dates for shareholders to pay attention to, as follows:

1. Announcement date, usually the date of the issuance of the GMS and the announcement of the distribution of dividends;
2. Tanggal ex-dividen, merupakan tanggal apabila terjadinya peralihan kepemilikan baru tidak lagi berhak atas dividen, biasanya berlangsung satu sampai dua hari kerja sebelum tanggal pencatatan. Tanggal ini penting untuk menentukan siapa yang berhak atas dividen yang dibayarkan;
3. Tanggal pencatatan, merupakan tanggal perusahaan membuat memorandum pencatatan dividen tunai untuk mengidentifikasi pemegang saham yang berhak atas dividen. Pada saat itu, perusahaan tidak perlu melakukan pencatatan akuntansi berupa penjurnalan, namun membuat catatan yang bersifat administrasi;

4. Tanggal pembayaran, merupakan tanggal pembayaran dividen kepada pemegang saham.

### Dividen Cash

According to Dwi Martani, et al (2015) the company distributes cash to shareholders in a certain proportion, referring to the ratio of dividends to net income. There are several considerations of the company in providing dividends.

1. Have the conditions stated in the agreement with the creditor;
  2. Meet the requirements of the founder of the company;
  3. Meet the funding needed by the company in the context of further growth or expansion
  4. Creating a stable dividend distribution scheme (smoothing out)
- Creating a cushion (reserve) for potential losses faced by the company in the future.

The formula for finding cash dividends can be measured by the following formula:

$$\text{Dividen Per Share} = \frac{\text{Total dividends distributed}}{\text{number of shares outstanding}}$$

Source, Francis (2016)

### Conceptual Framework

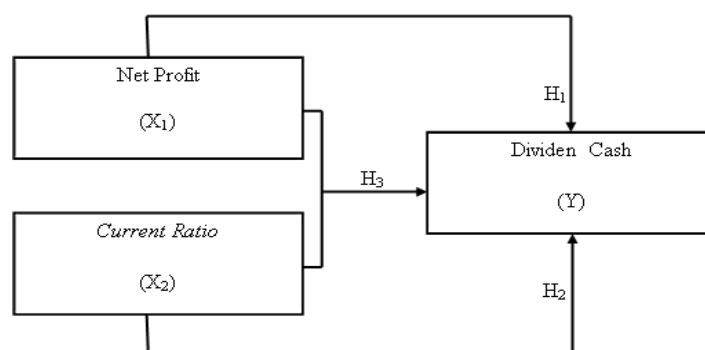

### Hypothesis

H<sub>1</sub>: Allegedly net profit effect on cash dividends

H<sub>2</sub>: Allegedly current ratio effect on cash dividend

H<sub>3</sub>: Estimated net income and current ratio effect on cash dividend

### RESEARCH METHODS

#### Data Type

The type of data used in this study is quantitative data, namely data obtained in the form of numbers. The quantitative data in this study is sourced from the Financial Statements of the coal mining sub-sector manufacturing companies which were officially released by the Indonesia Stock Exchange website for the period 2012-2016.

#### Data source

The source of data that the author uses in this study is secondary data, namely research sources obtained indirectly through intermediary media. As an empirical study, the secondary data in this study were obtained from journals, articles and previous studies.

#### Population

The population in this study are coal mining sub-sector manufacturing companies listed on the Indonesia Stock Exchange for the period 2012-2016, totaling 24 companies.

### Sample

Determination of the sample in this study is to use a purposive sampling technique, namely the method of selecting samples based on certain criteria in accordance with the research objectives. The following are the names of the companies that are sampled in this study, namely:

**Kriteria Sampel Penelitian**

No	Keterangan	Jumlah
1	Jumlah perusahaan manufaktur sub sektor pertambangan batubara yang terdaftar di BEI periode 2012-2016	24
2	Jumlah perusahaan manufaktur sub sektor pertambangan batubara yang tidak mengeluarkan laporan tahunan 2012-2016	1
3	Jumlah perusahaan manufaktur sub sektor pertambangan batubara yang tidak membagikan dividen minimal selama empat periode dari 2012-2016	17
<b>Jumlah sampel</b>		<b>6</b>

By looking at some of the criteria above, the number of samples used in this study is 6 companies.

### Variable Operational Definition

#### 1. Dependent Variable (Y)

In this study, the dependent variable is cash dividends, namely the company distributes cash to shareholders in a certain proportion, referring to the dividend distribution ratio, from net income, these variables can be influenced by Net Profit and Current Ratio because they can have a strong influence on variations in cash dividends.

#### 2. Independent Variable (X)

The independent variables of this study are:

a. Net Profit ( $X_1$ )

Net profit or net income after income tax is obtained by deducting pre-tax profit or income with income tax that must be paid by the company, finally containing information about the company's operating results, namely net profit/loss, which is the result of income minus expenses to be paid by the company.

b. Current Ratio ( $X_2$ )

Current Ratio is a ratio that shows the ability of a company to meet its obligations which are due immediately when billed in its entirety using current assets and current liabilities.

### Analysis Method

#### 1. Classic assumption test

a. Normality test

The normality test aims to test whether in the regression model, the confounding or residual variables have a normal distribution.

b. Multicollinearity Test

The multicollinearity test aims to test whether the regression model found a strong enough correlation between the independent variables. A good regression model should not have a strong enough correlation between the independent variables.

### c. Heteroscedasticity Test

Heteroscedasticity test aims to determine whether in the regression model there is an inequality of variance from the residual of one observation to another observation. A good regression model is the one with homoscedasticity or the one with no heteroscedasticity.

### d. Autocorrelation Test

The autocorrelation test aims to test whether in the linear regression model there is a correlation between the confounding error in period  $t$  and the confounding error in period  $t-1$  (previous).

## 2. Multiple Linear Regression Analysis

The multiple linear regression equation model in this study is:

$$Y = + NP1.X1 + CR.X2 + e$$

Information :

Y = Cash Dividend

□ = Constant

□ = Regression coefficient

e = Error

X1 = Net Profit (NP)

X2 = Current Ratio(CR)

## 3. Coefficient of Determination Analysis( $R^2$ )

The coefficient of determination ( $R^2$ ) test is used to measure how far the model's ability to explain the variation of the dependent variable is. The value of the coefficient of determination is between zero and one ( $0 < R^2 < 1$ ). A small value of  $R^2$  means that the ability of the independent variables to explain the dependent variable is very limited. The value of  $R^2$  that is close to one (1) means that the independent variables provide almost all the information needed to predict the variation of the dependent variable (Imam Ghozali, 2016).

## Hypothesis Testing Method

### 1. t test

The regression coefficient significance test (t test) was conducted to test whether an independent variable partially had a significant effect or not on the dependent variable and also to test the significance of the constants of each variable for decision making in accepting or rejecting the research hypothesis that the author had previously made. The decision-making criteria in this test according to Imam Ghozali (2016) is if the p value  $< 0.05$  then  $H_a$  is accepted. On the other hand, if the p value  $> 0.05$ , then  $H_a$  is rejected.

### 2. F Uji test

Simultaneous Test (F test) is used to show whether all independent variables (independent) namely the level of compliance, understanding and firmness of tax sanctions included in the regression model have a simultaneous (simultaneous) effect on the dependent variable, namely cash dividends. Criteriadecision making in tests that use (p value) or F count according to Imam Ghozali (2016) is if p value  $< 0.05$  or F count  $> F$  table then  $H_a$  is accepted. On the other hand, if the p value  $> 0.05$  or F count  $< F$  table, then  $H_a$  is rejected.

## RESULTS AND DISCUSSION

In this study, two independent variables (Net Profit and Current Ratio) have an effect on the dependent variable (Cash Dividend). Statistically it was done by testing either partially or simultaneously with the regression model using SPSS 23 software.

### 1. Classic assumption test

#### a. Normality test

**Tabel 1. First Normality Test Results**

		Unstandardized Residual
N		30
Normal Parameters <sup>a,b</sup>	Mean	0,0000000
	Std. Deviation	707,36019615
Most Extreme Differences	Absolute	0,292
	Positive	0,292
	Negative	-0,165
Test Statistic		0,292
Asymp. Sig. (2-tailed)		0,000 <sup>c</sup>

a. Test distribution is Normal.  
 b. Calculated from data.  
 c. Lilliefors Significance Correction.

From the results of the normality test above with Kolmogrove-Smirnovseen that the value of Asymp.Sig. (2-tailed) of 0.000 which means it is smaller than 0.05. These results can be concludedthat the data in this study were not normally distributed, then a second test was carried out by transforming the data (log 10) on the variables X1, X2, and Y. The results of the second test can be seen in the table below:

**Table 2. Second Normality Test Results**

		Unstandardized Residual
N		30
Normal Parameters <sup>a,b</sup>	Mean	,0000000
	Std. Deviation	,03234253
Most Extreme Differences	Absolute	,106
	Positive	,106
	Negative	-,076
Test Statistic		,106
Asymp. Sig. (2-tailed)		,200 <sup>c,d</sup>

a. Test distribution is Normal.  
 b. Calculated from data.  
 c. Lilliefors Significance Correction.  
 d. This is a lower bound of the true significance.

From the results of the second normality test with Kolmogrove-Smirnovseen that the value of Asymp.Sig. (2-tailed) of 0.200 which means greater than 0.05. These results can be concludedthat the data in this study are normally distributed.

#### b. Test Multicollinearity

**Table 3. Test Multicollinearity**

Model	Collinearity Statistics	
	Tolerance	VIF
(Constant)		
net profit	0.992	1.008
current ratio	0.992	1.008

a. Dependent Variable: DPS



Based on the test results Variance Inflation Factor (VIF) on the SPSS 23 Coefficients Output Results table, it is known that the VIF value of each independent variable has a VIF value  $< 10$  and a Tolerance value  $> 0.10$ , it can be concluded that the multiple linear regression model does not have multicollinearity between the dependent variable and the independent variable. So that the regression model is feasible or can be used in research.

**c. Test Heteroscedasticity**

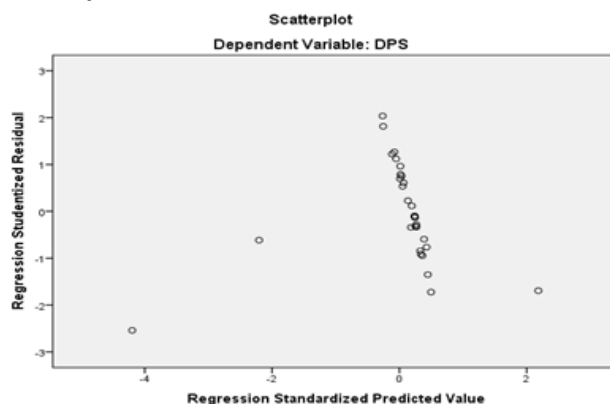

In the picture (scatter plot) there is no clear pattern, and the points spread above and below the number 0 on the Y axis. It can be concluded that there is no heteroscedasticity. This means that there is no heteroscedasticity in the regression model, so the regression model is feasible to use in this study.

**d. Autocorrelation Test**

Model Summary <sup>a</sup>					
Model	R	R Square	Adjusted R Square	Std. Error of the Estimate	Durbin-Watson
1	0,993 <sup>a</sup>	0,986	0,985	0,03352	0,976

a. Predictors: (Constant), current ratio, laba bersih  
b. Dependent Variable: DPS

From the table above, it can be seen that the DW value is 0.976. This value is then compared with the value of the Durbin Watson (DW) table using a significance value of 5%, the number of samples is 30 ( $n = 30$ ) and the number of independent variables is 2 ( $k = 2$ ), then from the Durbin-Watson table the lower limit value ( $d_l$ ) is 1.284, the upper limit value ( $d_u$ ) is 1.567 and the value  $(4 - d_u)$  is 2.2433. Because the DW value is 0.976, it is greater than 0 and smaller than  $d_l$  and the results are included in the criteria  $0 < d < d_l$  ( $0 < 0.976 < 1.284$ ), then it can be concluded that the data in the model there is a positive autocorrelation problem.

To overcome the autocorrelation problem, corrective action was taken, namely the transformation of variables using the Cochrane Orcutt method based on Durbin Watson statistics. After going through the data processing with one autocorrelation transformation, the output of Durbin Watson's calculation is as follows:

Model Summary <sup>b</sup>					
Model	R	R Square	Adjusted R Square	Std. Error of the Estimate	Durbin-Watson
1	0,993 <sup>a</sup>	0,985	0,984	0,02907	1,750

a. Predictors: (Constant), current ratio, laba bersih  
b. Dependent Variable: DPS



From the table above, it can be seen that the DW value is 1.750. This value is then compared with the value of the Durbin Watson (DW) table using a significance value of 5%, the number of samples is 30 (n = 30) and the number of independent variables is 2 (k = 2), then from the Durbin-Watson table the lower limit value (dl) is obtained.) is 1.284, the upper limit value (du) is 1.567, and the value (4-du) is 2.2433.

Because the DW value is 1.750 greater than the upper limit (du) 1.567, and less than 2.2433 (4-du) and the result is included in the criteriadu < d < 4-du (1.567 < 1.750 < 2.2433), then it can be concluded that regression model free from autocorrelation, so that the regression model is feasible to use.

## 2. Multiple Linear Regression Analysis

Hasil Analisis Regresi Berganda

Model	Coefficients <sup>a</sup>					Collinearity Statistics	
	Unstandardized Coefficients		Standardized Coefficients	t	Sig.	Tolerance	VIF
	B	Std. Error	Beta				
1 (Constant)	-0,003	0,014		-,207	0,838		
laba bersih	0,089	0,002	0,996	42,382	0,000	0,992	1,008
current ratio	0,077	0,033	0,055	2,320	0,028	0,992	1,008

a. Dependent Variable: DPS

From the table above, the results of multiple linear regression are obtained as follows:  $DK = -0.003 + 0.089 LB + 0.077 CR$

From the above regression equation can be described as follows:

- Constant (Absolute value of DK) if net income, and current ratio = 0, then the cash dividend is -0.003.
- LB regression coefficient (Net Profit) of 0.089 which means that there is a positive relationship between net profit with cash dividends, if net profit an increase of one unit will cause an additional cash dividend of 0.089 units, if the other independent variables are constant.
- The regression coefficient of CR (Current Ratio) is 0.077, which means that there is a positive relationship between current ratio with cash dividend, if current ratio increases by one unit, the cash dividend will cause an increase of 0.077 units, if the other independent variables are constant.

## 3. Coefficient of Determination Analysis (R<sup>2</sup>)

Hasil Analisa Koefisien Determinasi

Model	Model Summary <sup>b</sup>				
	R	R Square	Adjusted R Square	Std. Error of the Estimate	Durbin-Watson
1	0,993 <sup>a</sup>	0,985	0,984	0,02907	1,750

a. Predictors: (Constant), current ratio, laba bersih

b. Dependent Variable: DPS

From the table above, the coefficient of determination (Adjusted R Square) is 0.984. This means that the net profit variance and current ratio can explain cash dividends of 98.4%. While the rest, which is 100% - 98.4% = 1.6%, is explained by factors other than the variables studied above.

## Hypothesis Testing Results

### 1. t test

Hasil Perhitungan Uji-t

Model	Coefficients <sup>a</sup>						
	Unstandardized Coefficients		Standardized Coefficients	t	Sig.	Collinearity Statistics	
	B	Std. Error	Beta			Tolerance	VIF
1 (Constant)	0,-003	0,014		-0,207	0,838		
laba bersih	0,089	0,002	0,996	42,382	0,000	0,992	1,008
current ratio	0,077	0,033	0,055	2,320	0,028	0,992	1,008

a. Dependent Variable: DPS

Sumber: Hasil Output SPSS 23, diolah Penulis (2018)

The magnitude of used in this test is 5% ( $\alpha = 0.05$ ). With  $n = 30$  ;  $k = 3$  ;  $df = 27$  (30-3). So the value of the t-table is 2.052.

From the table above, the results of the t-test calculation can be described as follows:

#### 1. Variable Effect Net Profit Against Cash Dividend

H1: It is suspected that net income has a significant effect on cash dividends

Based on the results of the t-test above, the t-value is 42,382 > t-table 2.052 with a significant value of 0.000 where the significant value is <0.05. This shows that H<sub>1</sub> is accepted, meaning net income has a significant effect on cash dividends.

#### 2. Variable Effect Current Ratio Against Cash Dividend

H<sub>2</sub>: Allegedly current ratio significant effect to cash dividends

Based on the results of the t-test above, the t-value is 2.320 > t-table 2.052 with a significant value of 0.028 where the significant value <0.05. This shows that H<sub>2</sub> is accepted, meaning that the current ratio has a significant effect on cash dividends.

### 2. F Uji test

Hasil Perhitungan Uji-F

ANOVA <sup>a</sup>						
Model		Sum of Squares	df	Mean Square	F	Sig.
1	Regression	1,519	2	0,760	899,127	0,000 <sup>b</sup>
	Residual	0,023	27	0,001		
	Total	1,542	29			

a. Dependent Variable: DPS

b. Predictors: (Constant), current ratio, laba bersih

The magnitude of used in this test is 5% ( $\alpha = 0.05$ ). With  $n = 30$ ;  $df1 = 2$  (3-1);  $df2 = 27$  (30-3).

From the table above, the F value is 899.127 > F-table 3.35 with a significance level of 0.000 where the significance value is <0.05. This shows that H<sub>3</sub> is accepted, meaning net income, and current ratio have a significant effect simultaneously on cash dividends.

## Discussion

### 1. Effect Of Net Profit On Cash Dividend

Profit before income tax deducted by income tax will result in a net profit or loss. This net profit or loss provides users of financial statements with a summary measure of the company's overall performance during the current period (which includes both primary and secondary activities) and after calculating the amount of income tax.

Based on the results of the t test for the net income variable, obtained t value of 42,382 > t-table 2.052 with a significant value of 0.000 where the significant value is

$<0.05$ . This shows that the first hypothesis ( $H_1$ ) proposed is accepted, meaning that net income has a significant effect on cash dividends.

From the test results obtained a positive t value which indicates that net income has a unidirectional relationship with cash dividends, meaning that if net income increases, the company will experience an increase in its ability to provide cash dividends to coal mining sub-sector companies listed on the Indonesia Stock Exchange for the period 2012 -2016.

The results of this study are supported by the theory of Hery and Widyawati (2013) which states that companies that have a fairly good level of profit, from one period to the next, usually have the potential to distribute part of the net income to the company owners (shareholders). The distribution of net income to shareholders is done in the form of dividends.

The results of this study are in accordance with the results of research conducted by Aldhy Akbar Blue (2017), Mira Lestari (2014), Deisy Deborah Wenas, Hendrik Manosoh, and Victorina Z. Tirayoh (2017), Riyondi Tiocandra (2015), Herlas Tia Dekayani (2014), Muhammad Ridha Ramli and Muhammad Arfan (2011), Wahyuni and Subagyo (2013) stated that net income has a significant effect on cash dividends.

## **2. Influence Current Ratio Against Cash Dividend**

Current Ratio is a ratio that shows the ability of a company to meet its obligations which are due immediately when billed in its entirety using current assets and current liabilities. Based on the results of the t-test that has been carried out, the t-count value is  $2.320 > t\text{-table} 2.052$  with significant value of  $0.028$  where the significant value is  $> 0.05$ . This shows that the second hypothesis ( $H_2$ ) proposed is accepted, meaning that the current ratio has a significant effect on cash dividends.

From the test results obtained a positive t value which indicates that the current ratio has a direct relationship with cash dividends. This means that the higher the company's current ratio, the higher the cash dividend in coal mining sub-sector companies listed on the Indonesia Stock Exchange for the period 2012-2016.

The results of this study are supported by the theory of According to Sartono (2012) which states that the greater the cash and liquidity position, the greater the company's ability to pay dividends. The results of this study are also the same as the results of Herlas Tia Dekayani (2014) which states that current ratio has a significant effect on cash dividends in coal mining companies and has a positive relationship, which means the greater the current ratio, the higher the cash dividend.

## **3. Influence Simultaneous Net Profit, And Current Ratio To Dividends**

Based on the results of the F test of  $899.127 > F\text{-table} 3.35$  with a significance level of  $0.000$  where the significance value is  $<0.05$ . This shows that  $H_3$  is accepted, meaning net income, and current ratio have a significant effect simultaneously on cash dividends.

With a coefficient of determination (Adjusted R Square) of  $0.984$ . This means that the net profit variance and current ratio can explain cash dividends of  $98.4\%$ . While the rest is equal to  $100\% - 98.4\% = 1.6\%$  is explained by factors other than the variables studied. The results of this study shows that net income and current ratio simultaneously have a significant effect on cash dividends.

Hasil penelitian ini sesuai dengan penelitian yang dilakukan oleh Lusi Septriana, Prima Aprilyani Rambe, dan Hj. Asmaul Husna yang menyatakan bahwa laba akuntansi, laba tunai, arus kas bebas, arus kas operasional, leverage, dan current ratio, secara simultan berpengaruh terhadap dividen kas.

## CONCLUSION AND RECOMMENDATION

### Conclusion

Berdasarkan hasil analisis dan pembahasan yang telah dijelaskan pada bab sebelumnya, maka peneliti dapat menarik suatu kesimpulan sebagai berikut:

1. Laba Bersih berpengaruh signifikan terhadap Dividen Kas pada perusahaan manufaktur sub sektor pertambangan batubara yang terdaftar di Bursa Efek Indonesia (BEI) periode 2012-2016. Hal ini ditunjukkan oleh nilai t-hitung sebesar 42,382 dengan nilai signifikan sebesar 0,000 dimana nilai signifikannya  $< 0,05$ .
2. Current Ratiosignificant effect on Cash Dividend in coal mining sub-sector manufacturing companies listed on the Indonesia Stock Exchange (IDX) for the period 2012-2016. This is indicated by the t-count value of 2.320 with a significant value of 0.028 where the significant value is  $< 0.05$ .
3. Net profitand Current Ratio has a significant effect on dividendsCash in coal mining sub-sector manufacturing companies listed on the Indonesia Stock Exchange (IDX) for the period 2012-2016. This is shown byF-count value 899.127with levelsignificance of 0.000 where the significance value  $< 0.05$ .

### Suggestion

From the results of the analysis and conclusions obtained, the authors can put forward the following suggestions:

1. It is advisable for the company to pay attention to the company's net income and current ratio because it has a significant influence on the company's cash dividends and pay attention to the amount of income and pay attention to the current ratio level, this is useful in determining decisions in the distribution of cash dividends in the future by emphasizing the amount of company debt, so that the allocation of funds for debt repayment can be allocated to cash dividends for company development, as well as the high level of current ratio in a company will affect the company's management policy in distributing dividends to investors because with increased profits and current ratio, investors are more interested in investing in the company. the.
2. For future researchers, it is recommended to further expand the population area, not only focusing on coal mining sub-sector manufacturing companies listed on the Indonesia Stock Exchange, but also expanding to other sector companies.

## BIBLIOGRAPHY

- A. Sartono, 2012 Financial Management: Theory and Application. Edition 4, BPFE, Yogyakarta.
- Aldhy Akbar Lazuard, 2017, Cash Dividend Affected by Net Profit and Cash Ratio(Survey of Mining Sector Companies listed on the Indonesia Stock Exchange 2010-2014). Thesis Faculty of Economics and Business: Indonesian Computer University.
- Deisy Deborah Wenas, Hendrik Manosoh,andVictorina Z. Tirayoh. 2017. Analysis of the Effect of Operating Cash Flow and Net Profit on Cash Dividends in Property Companies Listed on the Indonesia Stock Exchange (IDX),Journal of EMBA Vol.5 No.1 March 2017, p. 96 – 104.
- Dwi Martani, et al, 2015, PSAK-Based Medium Financial Accounting, Salemba Empat, Jakarta.
- Fransiskus Paulus Paskalis Abi, 2016, Getting Closer to the Indonesian Capital Market, Edition 1, Issue 1, Deepublish, Yogyakarta.
- Herlas Tia Dekayani, 2014, Effect of Net Profit and Current Ratio on Cash Dividends in Coal Mining Companies Listed on the Indonesia Stock Exchange (IDX).Thesis, Faculty of Economics: Indonesian Computer University.

- Hery, SE, M.Si 2012, Analysis of Financial Statements 2, First Printing, Bumi Aksara, Jakarta.
- Hery, SE, M.Si and Widiyawati Iekok, SE, MM, 2013, Intermediate Financial Accounting 2, Second Printing, Bumi Aksara, Jakarta
- Imam Ghozali, 2016, Application of Multivariate Analysis with IBM SPSS 21 Program, UNDIP, Semarang.
- Kasmir, 2016, Analysis of Financial Statements, Ninth Edition One Printing, PT. Raja Grafindo Persada, Jakarta.
- Luluk Muhimatul Ifada and Nia. 2014. The Effect of Net Profit and Operational Cash Flow, Investment Opportunity Set and Firm Size on Cash Dividends (Case Study of Manufacturing Companies in Indonesia Stock Exchange 2010-2012). Journal of Accounting Dynamics. Volume 6 No. September 2, 2014. ISSN 2085-4277
- Lusi Septriana, Prima Aprilyani Rambe, and Hj. Asmaul Husna. 2016. The Effect of Accounting Profit, Cash Profit, Free Cash Flow, Operating Cash Flow, Leverage, and Current Ratio, on Cash Dividends in Manufacturing Companies Listed on the Indonesia Stock Exchange in 2012-2014. Thesis Faculty of economics: Raja Ali Haji Maritime University. Tanjung Pinang, Riau Islands.
- Mira Lestari, 2014, Effect of Net Profit and Free Cash Flow on Cash Dividend (Case Study on Mining Sector Companies Listed on the Indonesia Stock Exchange for the Period 2008-2013). Thesis of Faculty of Economics: Indonesian Computer University
- Muhammadd Rida Ramli and Muhammad Arfan. 2011. Effect of Profit, Operating Cash Flow, Flow of Syiah Kuala University by Shareholders. Journal of Accounting Studies and Research Vol. 4 No.2 July 2011 Pages 126 - 138.
- Riyondi Tiocandra. 2015. Analysis of the Effect of Net Profit, Operating Cash Flow, Previous Cash Dividend Payments, and Quick Ratio on Cash Dividends in Lq-45 Companies Listed on the Indonesia Stock Exchange. Journal of Let's FEKON Vol 2 No. October 2, 2015.
- Wahyuni and Subagyo, 2013, Effect of Accounting Profit, Operating Cash Flow and Company Liquidity on Cash Dividend Payments, Journal Cahaya Aktiva Vol.03 No.01, March 2013.