



+62 813 8765 4578

+62 813 8765 4578

<https://dinastipub.org/DIJDBM>

dinasti-info@gmail.com

## THE EFFECT OF INTERNAL AND EXTERNAL FACTORS ON ENTREPRENEURIAL INTEREST MEDIATED BY ENTREPRENEURSHIP EDUCATION ON STUDENTS OF AN NAJIYAH VOCATIONAL SCHOOL TANGGERANG OF 2019/2020 ACADEMIC YEAR

**Tyas Siswiandini**

Masters in Management, University of Mercu Buana Jakarta

### ARTICLE INFORMATION

Received: 18<sup>th</sup> July 2020

Revised: 26<sup>th</sup> July 2020

Issued: 22<sup>th</sup> August 2020

Corresponding author: First Author

E-mail:

[tyasandin@gmail.com](mailto:tyasandin@gmail.com)



DOI:10.31933/DIJDBM

**Abstract:** Unemployment in Indonesia continues to increase every year. One cause of the unemployment problem is school graduates who have the goal of finding jobs, not developing more jobs. One step in reducing unemployment and increasing employment is by entrepreneurship through entrepreneurship education. An Najiyah Tangerang Vocational School is one of the schools that provide the entrepreneurial understanding and hands-on learning practice. This study aims to determine the effect of internal and external factors on entrepreneurial interest mediated by entrepreneurship education on students of An Najiyah Vocational School Tangerang. This study used a quantitative approach with data analysis in testing the measurement model and the structural model using SmartPLS software version 3.2.8. The results showed that internal and external factors had a significant positive effect on entrepreneurship education and entrepreneurial interest on students of An Najiyah Vocational School. If the internal and external factors were mediated by the variable of entrepreneurship education, the effect was significant on entrepreneurial interest. In addition, entrepreneurship education also has a significant positive effect on the entrepreneurial interest of An Najiyah Vocational School.

**Keywords:** Internal Factors, External Factors, Entrepreneurial Interest, Entrepreneurship Education.

### INTRODUCTION

Unemployment in Indonesia continues to increase every year. In February 2017, the number of work generation amounted to 113.9 million along with total unemployment of 68.7 million as well as the work generations of 127.07 million. In 2018, the total of work generation increased by 2.39 million. Graduates of vocational High School (SMK) give the highest share of unemployment, which is 8.92% when viewed from the level of education (<https://www.bps.go.id/>).

One of the causes of many unemployment problems is a large number of school or college graduates whose sole purpose is to find jobs, not to add more jobs. The students' insights and abilities

gained at the Vocational High School (SMK) not only become a basic asset for students to prepare in the working world but are also used to prepare students to become entrepreneurs. An Najiyah Vocational School Tangerang is one of the Islamic Private Vocational Schools located in South Tangerang City. An Najiyah Vocational School Tangerang provides an entrepreneurial understanding and hands-on learning practices and always strives to carry out the vision and mission of the vocational school both in terms of learning and providing training to students in encouraging the attainment of specific goals of vocational school.

Entrepreneurship education with a diverse educational environment is expected to advance the culture of entrepreneurship, advertise the establishment of new businesses, and can support entrepreneurial thinking with education and learning (Kuratko, 2005 in Budi, 2018). The purpose of entrepreneurship education is to make students can learn in understanding entrepreneurship, learning to get an entrepreneurial spirit, and learning to become an entrepreneur.

Based on the above phenomenon, the researcher wanted to conduct a study on the Effect of Internal and External Factors on Entrepreneurial Interest Mediated by Entrepreneurship Education on Students of An Najiyah Vocational School Tangerang in 2019/2020 Academic Year. The researcher had conducted a pre-survey before on the students of AN Najiyah Vocational School Tangerang, and the following results were obtained:

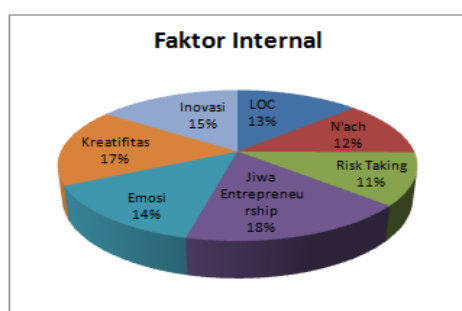

Figure 1. Internal Factors

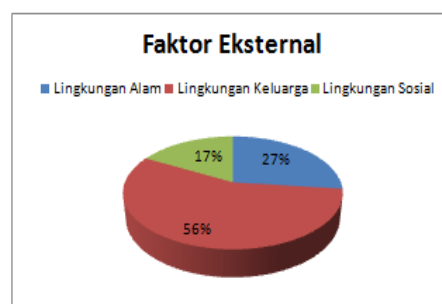

Figure 2. External Factors

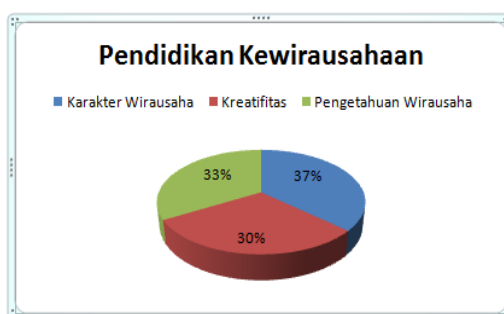

Figure 3. Entrepreneurship Education

## LITERATURE REVIEW

### Entrepreneurship

Entrepreneurship is an innovative and creative capability which is used as a starting point, strategy, and resource to find opportunities to succeed. The subject of entrepreneurship is the capability to create something new and diverse with creative ideas as well as innovation to realize opportunities. Many entrepreneurs and non-entrepreneurs achieve success because they have creative and innovative capabilities (Suryana, 2010 in Ine Ruswati, 2018). Whereas according to (Havidz Aima, 2015 in Zaenal Afandi, 2019) entrepreneurship is a creative and innovative ability that is the basis for it, a tip and a resource to find opportunities for success. The point is the ability to create something new and different through creative thinking and innovative acting to look for opportunities in the face of life's challenges.

**Internal factors**

Suhartini (2011) stated that internal factors are existing factors caused by the effect of encouragement in human beings themselves. Internal factors include creativity, innovation, emotion, Locus of Control (LOC), Need of Achievement (N'ACH), Risk-Taking, and the Soul of Entrepreneurship. The internal factors used by the researcher as dimensions of internal factors include the Soul of Entrepreneurship and Creativity (Chairy, 2011 in Ine Ruswati, 2018). According to Nickels (2005), the Soul of Entrepreneurship is possessed by a person who seeks to have an entrepreneurial spirit. According to Alma (2008), creativity is the expertise to create new combinations and pay attention to the new links between variable data components that already exist.

**External Factors**

External factors are factors that originate from outside oneself or a person. According to Walgito (2004) in Hengky Widhiandono (2016), Convergence Theory explains that the environment has a vital position in one's development. Reality often happens to prove this theory. A person or individual who grows up in the scope or business environment will tend to have more opportunities to become an entrepreneur. And this also applies to other individuals who grow up in the scope or environment of farmers, employees, teachers, fishermen, and so on. Generally, the environment can be explained into two, including the natural and social environment.

**Entrepreneurship Education**

Entrepreneurship education has the aim to improve students' insights and understanding of entrepreneurship through attitudes, knowledge, and expertise to overcome the complexities embedded in entrepreneurial tasks (Fiet, 2000; Segal et al, 2005 in Yudi Siswadi, 2013). Through education, the knowledge gained by individuals will make a person more confident, intellectual, have good character, innovative, creative, able to choose and make the right decisions, moral, and improve the quality of other resources so that they will be able to work on their own. Education has a function in shaping a person's personality to become stronger and resilient. A strong personality can also be one of the basic steps for an entrepreneur (Widhiandono, Hengky 2016).

**Entrepreneurial Interest**

Entrepreneurial interest is described as the will, interest, and desire to always work hard to meet needs without fear of risk (Fu'adi, Eko, & Murdani, 2009). Factors affecting entrepreneurial interest are subjective norms. Subjective norms are generated by the existence of normative beliefs and a willingness to follow. Normative beliefs are related to expectations originating from a person or group of people that influence individuals (significant others) such as parents, friends, spouses, colleagues, and others, depending on the behavior carried out (Ajzen, 2005 in I Made Yudi, 2016). Then, the factor of personal attitude consists of age, gender, and personal experience or experiences that change some manners (Amofah, 2006). The next factor, Perceived Behavior Control, is described as the expertise in individuals to carry out a behavior. Perceived Behavioral Control reflects a person's belief in how easily an individual is able to show behavior.

**Framework**

One of the causes of the many unemployment problems is the large number of school graduates whose sole purpose is to find jobs, not to add more jobs. The students' insights and abilities gained at the Vocational High School (SMK) not only become a basic asset for students to prepare in the working world but are also used to prepare students to become entrepreneurs. An Najiyah Vocational School is one of the Islamic Private Vocational Schools located in South Tangerang City. An Najiyah Vocational School Tangerang provides an entrepreneurial understanding and hands-on learning practices. Entrepreneurship education with a diverse educational environment is expected to advance the culture of entrepreneurship, advertise the establishment of new businesses, and can support entrepreneurial thinking with education and learning (Kuratko, 2005 in Budi, 2018). The purpose of

entrepreneurship education is to make students can learn in understanding entrepreneurship, learning to get an entrepreneurial spirit, and learning to become an entrepreneur.

Based on the description above, the researcher set a number of variables that are examined later, consisting of an independent variable (X), which is Internal Factors (X1), including the Soul of Entrepreneurship and Creativity. Meanwhile, the External Factors (X2) include the Natural Environment and Family Environment. Whereas, the dependent variable (Y) is Entrepreneurship Education (Y1), including Entrepreneurial Characteristics and Entrepreneurial Knowledge. Meanwhile, the Entrepreneurial Interest (Y2) includes Normative Belief, Personal Attitude, and Perceived Behavioral Control. So, the mindset in this study is as follows:

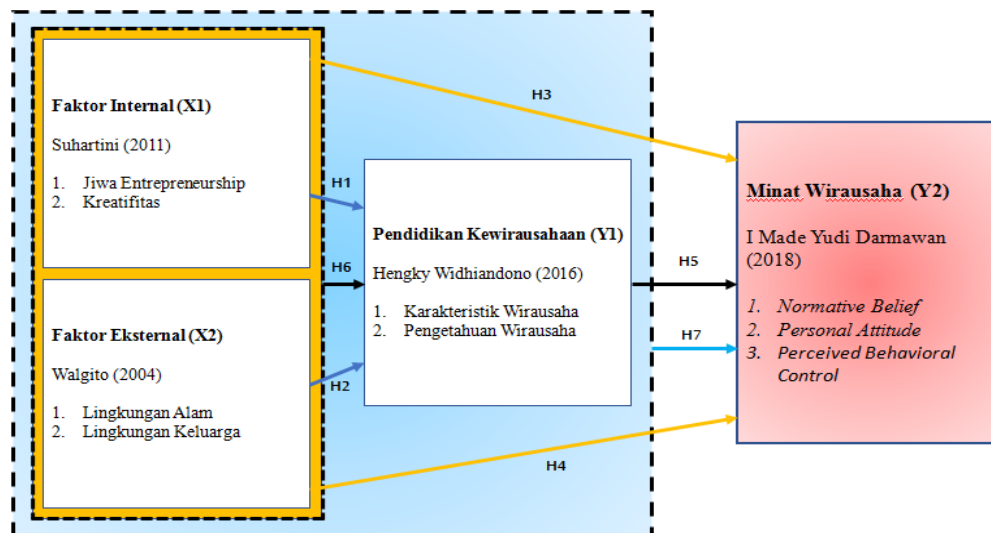

**Figure 4. Framework**

Referring to the mindset above, this study aimed to find out and explain about internal factors that have a significant effect on entrepreneurship education at An Najiyah Vocational School, External Factors that have a significant effect on entrepreneurship education at An Najiyah Vocational School, Internal Factors that have a significant effect on entrepreneurial interest at An Najiyah Vocational School, External Factors that have a significant effect on entrepreneurial interest at An Najiyah Vocational School, Entrepreneurship Education that has a significant effect on entrepreneurial interest at An Najiyah Vocational School, Internal Factors and External Factors that have a significant effect on entrepreneurship education at An Najiyah Vocational School, Internal Factors, External factors, and entrepreneurship education that have a significant effect on entrepreneurial interest at An Najiyah Vocational School, Entrepreneurship Education that significantly mediates the effect of internal and external factors on entrepreneurial interest at An Najiyah Vocational School.

#### Hypotheses

- Hypothesis 1 : Internal factors have a significant effect on entrepreneurship education at An Najiyah Vocational School
- Hypothesis 2 : External factors have a significant effect on entrepreneurship education at An Najiyah Vocational School
- Hypothesis 3 : Internal factors have a significant effect on entrepreneurial interest at An Najiyah Vocational School
- Hypothesis 4 : External factors have a significant effect on entrepreneurial interest at An Najiyah Vocational School
- Hypothesis 5 : Entrepreneurship Education has a significant effect on entrepreneurial interest at An Najiyah Vocational School
- Hypothesis 6 : Internal Factors and External Factors have a significant effect on Entrepreneurship education at An Najiyah Vocational School

- Hypothesis 7 : Internal factors, external factors, and entrepreneurial education have a significant effect on entrepreneurial interest at An Najiyah Vocational School
- Hypothesis 8 : Entrepreneurship Education significantly mediates the effect of internal factors and external factors on entrepreneurial interest at An Najiyah Vocational School.

## RESEARCH METHODS

The type of research used in this research was quantitative research. The data used in this study were primary data in the form of survey results. To collect complete, significant, and complementary data, in addition to primary data, the author also used secondary data. This research was conducted to understand, describe, and analyze the relationship between independent variables to the dependent variables. The analysis used in this study was relevant statistical data to test hypotheses. Therefore, the data obtained in this study could later provide a clear picture of the object under study, and later, a conclusion could be made. The research variables described in terms of dimensions, indicators, and question items as data collection instruments could be seen in Table 1.

**Table 1. Operational Variables**

Variable	Dimension	Indicator	No Item
<b>Internal Factors (X1)</b> Suhartini (2011)	The Soul of Entrepreneurship	a. Confident	1
		b. Action-oriented	2
		c. Tolerant of uncertainty	3
	Creativity	a. Optimistic	4
		b. Always curious	5
		c. Like to imagine	6
<b>External Factors (X2)</b> Walgitto (2004)	The natural environment	a. A residential location that supports business	7
		b. Natural wealth	8
		c. Season changes	9
	Family environment	a. Parents' job	10
		b. Parental support	11
		c. Economic status	12
<b>Entrepreneurship Education (Y1)</b> Hengky Widhiandono (2016)	Entrepreneurial Characteristics	a. Have commitment	13
		b. Have a work ethic	14
		c. Have an attitude of independence	15
	Entrepreneurial Knowledge	a. Able to communicate well	16
		b. Have management knowledge	17
		c. Have marketing knowledge	18
<b>Entrepreneurial Interest (Y2)</b> I Made Yudi Darmawan (2018)	<i>Normative Belief</i>	a. Desire	19
		b. Motivation to fulfill	20
		c. Concern	21
	<i>Personal Attitude</i>	a. Positive attitude	22
		b. Always want to try new things	23
		c. Persistent	24
<i>Perceived Behavioral Control</i>	a. Confidence	25	
	b. Dare to take risks	26	
	c. Self ability	27	

Source: Data processed by the researcher, 2020

## Population and Samples

The population in this study were all students of An Najiyah Vocational School that had received instruction in entrepreneurship subjects totaling 170 students. Therefore, to calculate the sample of An Najiyah Vocational School students, the Slovin formula was used with a leeway of 5%,

resulting in a total sample of 119. The sampling technique used in this study was simple random sampling on Probability Sampling. This type of sampling was a sampling system of a portion of the population done randomly regardless of the level in some populations (Sugiyono, 2014).

**Data analysis**

The data analysis method used in this research was the SmartPLS software version 3.2.8. Partial Least Square (PLS) was a study of structural equations on the basis of variance which together tested the measurement model and the structural model. Validity and reliability tests were carried out using a measurement model, while the causality test was carried out using a structural model.

**RESEARCH RESULTS AND DISCUSSION**

**Characteristics of Respondents**

Characteristics of respondents in this study are presented in Table 2 as follows:

**Table 2. Characteristics of Respondents**

No	Demographic Characteristics / Category	Frequency (people) / (percent)
1	Gender	
	a. Male	46 (38.65%)
	b. Female	76 (61.35%)
	Total	100 (100%)
2	Age	
	a. 18 Years	31 (26.06%)
	b. 17 Years	48 (40.33%)
	c. 16 Years	27 (22.69%)
	d. 15 Years	13 (10.92%)
	Total	119 (100%)
3	Grade Level	
	a. 12 <sup>th</sup> Grade	57 (45.90%)
	b. 11 <sup>th</sup> Grade	41 (34.45%)
	c. 10 <sup>th</sup> Grade	21 (17.65%)
	Total	119 (100%)

Source: Data processed by the researcher, 2020

**Evaluation of the Reflective Measurement Model (Outer Model) or Test Indicator**

Below is a picture of the calculation results of the measurement model with SEM PLS version 3.2.8 which is then viewed by the factor loading value on the indicators in each research variable. The loading factor value used in this study is >0.5. Therefore, if the loading factor value is <0.5, the calculation results of the measurement model (outer model) will be removed from the model.

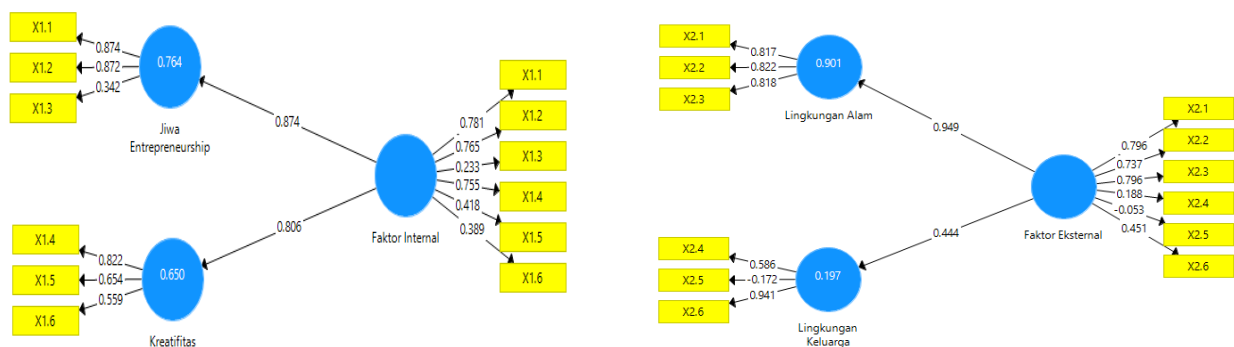

**Figure 5. Results of Calculations of Measurement Model**    **Figure 6. Results of Calculations of Model Measurement**



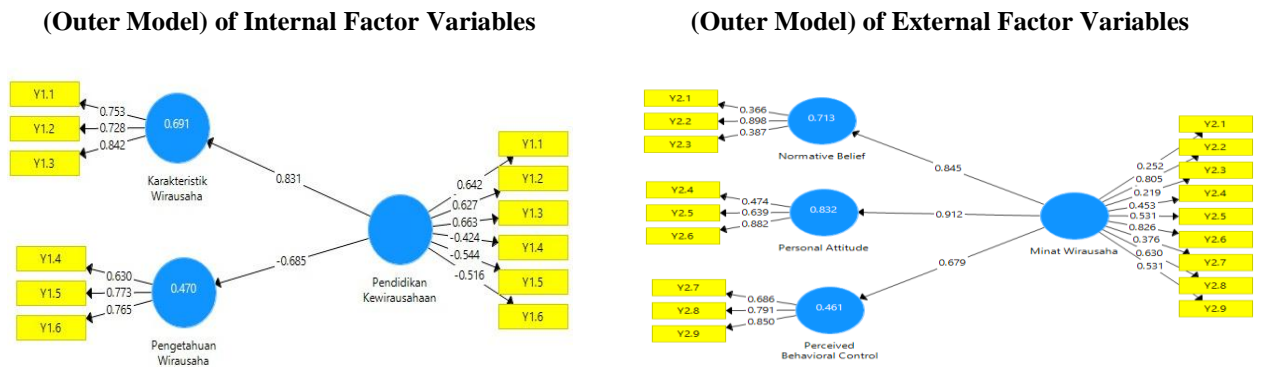

**Figure 7. Results of Calculations of Measurement Model (Outer Model) of Entrepreneurship Education Variable**

**Figure 8. Results of Calculations of Measurement Model (Outer Model) of Entrepreneurial Interest Variable**

Evaluation of convergent validity from the examination of Average variance extracted (AVE) illustrates the magnitude of variance or diversity of *variable manifest* that can be possessed by latent constructs. The greater the variance or diversity of *variable manifest* that can be contained by latent constructs, the greater the representation of variable manifest towards its latent constructs. Evaluation of convergent validity from the examination of Average Variance Extracted (AVE) can be seen from the value of AVE based on the results of data processing with SmartPLS version 3.2.8 in Table 3.

**Table 3. Average Variance Extracted (AVE) Value for Each Variable**

Variable	Average Variance Extracted (AVE)
Internal factors	0.658
External Factors	0.505
Entrepreneurship Education	0.589
Entrepreneurial Interest	0.584

Source: Data processed by researchers, 2020

Based on Table 3 above, it is known that all instruments have an AVE value >0.5, which is 0.658 for internal factors, 0.505 for external factors, 0.589 for entrepreneurship education, and 0.584 for entrepreneurial interest. And the AVE value >0.5 above shows a good measure of convergent validity.

Evaluation of convergent validity from internal consistency reliability checks can be seen from the Cronbach’s Coefficient Alpha and Composite Reliability (CR) values shown in Table 4.9. The table presented is the result of the SmartPLS calculation version 3.2.8.

**Table 4. Cronbach’s Coefficient Alpha and Composite Reliability (CR) Values**

Variable	Cronbach's Alpha	Composite Reliability
Internal factors	0.743	0.852
External Factors	0.500	0.749
Entrepreneurship Education	0.666	0.809
Entrepreneurial Interest	0.737	0.839

Source: Data processed by the researcher, 2020

A construct or variable is considered reliable if it has a Cronbach’s Alpha value in the range of 0.60 to 0.80 and is considered to be quite reliable (moderate) if it is in the range of 0.40 to 0.60, and Composite Reliability is above 0.80. From the SmartPLS output above, all constructs or variables have a Cronbach’s alpha values above 0.40 and composite reliability above 0.70. Therefore, it can be concluded that the construct or variable has fairly good reliability.

**Testing Discriminant Validity**

The validity of the indicators on each research variable can also be done by testing discriminant validity by checking the cross-loading value, which is the indicator correlation coefficient on its

construct compared to the correlation coefficient with other constructs. The correlation coefficient value of the indicator must be greater on the construct than the other constructs.

**Table 5. Results of Discriminant Validity Testing after Modification**

	Internal factors	External Factors	Entrepreneurship Education	Entrepreneurial Interest	Explanation
X1.1	0.862	-0.033	0.348	0.302	Valid
X1.2	0.845	0.082	0.347	0.293	Valid
X1.4	0.718	-0.089	0.241	0.184	Valid
X2.1	0.025	0.856	0.256	0.237	Valid
X2.2	-0.057	0.653	0.136	0.158	Valid
X2.6	0.001	0.598	0.220	0.179	Valid
Y1.1	0.311	0.256	0.858	0.849	Valid
Y1.2	0.395	0.226	0.617	0.256	Valid
Y1.3	0.239	0.209	0.807	0.512	Valid
	Internal factors	External Factors	Entrepreneurship Education	Entrepreneurial Interest	Explanation
Y2.2	0.222	0.217	0.714	0.931	Valid
Y2.5	0.303	0.161	0.359	0.555	Valid
Y2.6	0.263	0.243	0.784	0.948	Valid
Y2.8	0.301	0.240	0.384	0.509	Valid

Source: Data processed by the researcher, 2020

Based on the results of discriminant validity testing after modification of the model, as shown in Table 5 above, all indicators have a cross-loading value to the construct greater than the value of the cross-loading to other constructs. Therefore, it is declared valid. It can be concluded that the constructs of internal factors, external factors, entrepreneurship education, and entrepreneurial interest have fairly good discriminant validity.

**Evaluation of the Structural Model (Inner Model) or Hypothesis Test**

**Evaluating the Path Coefficient Value**

In evaluating the path coefficient, based on the results of calculations using SmartPLS version 3.2.8 bootstrapping, the path coefficient results obtained illustrate the strength of the relationship between constructs/variables as shown in Figure 9 as follows:

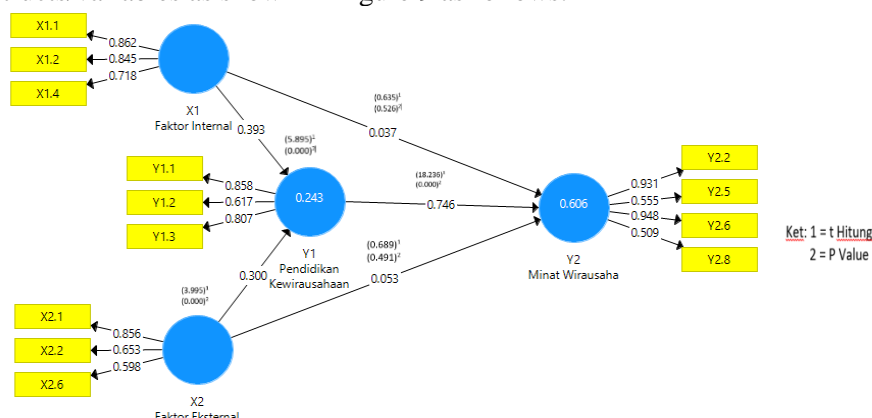

**Figure 9. The Results of Calculation of Bootstrapping Inner Measurement Model**

Source: Data processed by the researcher, 2020

Based on Figure 9, the structural equation of this research can be formulated as follows:

$$\begin{aligned} \text{Entrepreneurship Education} & (Y_1) = 0.393X_1 + 0.300X_2 \\ \text{Entrepreneurial Interest} & (Y_2) = 0.037X_1 + 0.053X_2 + 0.746\beta \end{aligned}$$

**Evaluating R<sup>2</sup> Value**

In evaluating the R<sup>2</sup> value based on the calculation results using the SmartPLS version 3.2.8 algorithm, the R<sup>2</sup> value is 0.243 for the entrepreneurship education variable and 0.606 for the



entrepreneurial interest variable. The  $R^2$  value shows that the level of determination of exogenous variables (internal factors and external factors) on the endogenous variables is quite high. The simultaneous effect of the variables of internal and external factors on entrepreneurship education can be done by calculating f count / f statistics using the formula as follows.

Entrepreneurship Education

$$R^2 = 0,243 \text{ (PK)}$$

$$F \text{ count} = \frac{\frac{R^2}{k-1}}{\frac{1-R^2}{n-k}}$$

$$F \text{ count} = \frac{\frac{0,243}{2-1}}{\frac{1-0,243}{119-2}}$$

$$F \text{ count} = 37,96875$$

$$F \text{ count} = 37,97$$

Entrepreneurial Interest

$$R^2 = 0,606 \text{ (MW)}$$

$$F \text{ count} = \frac{\frac{R^2}{k-1}}{\frac{1-R^2}{n-k}}$$

$$F \text{ count} = \frac{\frac{0,606}{3-1}}{\frac{1-0,606}{119-3}}$$

$$F \text{ count} = 91,81818$$

$$F \text{ count} = 91,82$$

Significant test results were simultaneously used to test hypotheses 6 and 7 in this study. The values of F count in this study is 37.97 and 91.82. The values F table at alpha 0.05 is 2.68. This means that f count > f Table (2.68), therefore, H6 and H7 are accepted.

### Measuring Effect Size $f^2$

The purpose of measuring the effect size  $f^2$  is to see the size of the effect of exogenous latent variables on endogenous latent variables or to see the goodness of the model. The results of the calculation of the effect size (f square) value with Smart PLS version 3.2.8 are shown in table 6 below.

**Table 6. Values of Effect Size  $F^2$**

	X1_Internal Factors	X2_External Factors	Y1_Entrepreneurship Education	Y2_Entrepreneurial Interest
X1_Internal Factors			<b>0.204 (Strong)</b>	<b>0.003 (Weak)</b>
X2_External Factors			0.119 (Adequate)	<b>0.006 (Weak)</b>
Y1_Entrepreneurship Education				<b>1.068 (Strong)</b>
Y2_Entrepreneurial Interest				

Source: Data processed by the researcher, 2020

### Validating the Overall Structural Model with the Goodness of Fit Index (GoF)

The purpose of testing the Goodness of Fit Index (GoF) is to validate the combined performance of the measurement model (outer model) and the structural model (inner model) obtained through calculations as follows:

$$GoF = \sqrt{AVE * R^2}$$

$$GoF = \sqrt{\frac{0.658 + 0.505 + 0.589 + 0.584}{4} * \frac{0.243 + 0.606}{2}}$$

$$GoF = \sqrt{0.584} \times 0.424$$

$$GoF = \sqrt{0.248}$$

$$GoF = 0.498$$

Based on these results, it can be concluded that the combined performance of the measurement model (outer model) and the structural model (inner model) as a whole is fairly good because the Goodness of Fit Index (GoF) value is more than 0.36 (large scale GoF).

### Predictive Relevance ( $Q^2$ ) Testing

The purpose of testing predictive relevance ( $Q^2$ ) is to validate the model. The results of the  $Q^2$  calculation are as follows:

$$Q^2 = 1 - (1 - R_1^2)(1 - R_2^2)$$

$$Q^2 = 1 - (1 - 0.243)(1 - 0.606)$$

$$Q^2 = 1 - (0.757)(0.394)$$

$$Q^2 = 1 - 0.2982$$

$$Q^2 = 0.702$$

Based on the results of the calculation above, the value of predictive relevance ( $Q^2$ ) is 0.702. In this research model, endogenous latent variables have a value of predictive relevance ( $Q^2$ ) greater than 0 (zero). Therefore, exogenous latent variables as explanatory variables can predict their endogenous variables, which is entrepreneurial interest or in other words, it proves that this model is considered to have good predictive relevance.

**The Results of the Effect of Independent Variables on Dependent Variables**

The results of statistical calculations with the SmartPLS program version 3.2.8 are shown in Table 4.15 and Table 7 below.

**Table 7. The Effect of Independent Variables on Dependent Variables Partially**

	Original Sample (O)	Sample Mean (M)	Standard Deviation (STDEV)	T Statistics ((O/STDEV))	T Tabel	P Values
X1_Internal Factors > Y1_Entrepreneurship Education	0.393	0.395	0.067	5.895	1,98081	0.000
X1_Internal Factors > Y2_Entrepreneurial Interest	0.037	0.036	0.058	0.635	1,98081	0.526
X2_External Factors > Y1_Entrepreneurship Education	0.300	0.306	0.075	3.995	1,98081	0.000
X2_External Factors > Y2_Entrepreneurial Interest	0.053	0.062	0.077	0.689	1,98081	0.491
Y1_Entrepreneurship Education -> Y2_Entrepreneurial Interest	0.746	0.750	0.041	18.236	1,98081	0.000

Source: Data processed by the researcher, 2020

**Table 8. The Effect of Independent Variables on Dependent Variables Simultaneously**

	R square	F Statistic	F Table	Alpha	Conclusion
(F1, F2) -> PK	0.243	37.97	2,68	0,05	FCount > FTable (H <sub>6</sub> is accepted)
(F1,F2, PK) -> MW	0.606	91.82	2,68	0,05	Count > FTable (H7 is accepted)

Source: Data processed by the researcher, 2020

Based on the table above, it can be concluded that the internal factors, external factors, and entrepreneurship education partially and simultaneously have a significant effect on the entrepreneurial interest at An Najiyah Vocational School. Entrepreneurship Education significantly mediates internal and external factors on the entrepreneurial interest of An Najiyah Vocational School.

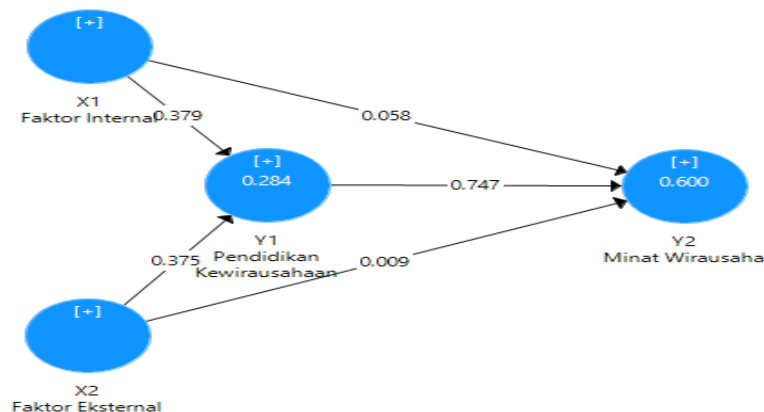

**Figure 10. Testing the Indirect Effect Model with Smart PIs**

Source: Primary data processed by the researcher (2020)

**Correlation Analysis Between Dimensions**

Correlation matrix between dimensions is intended to determine the dimensions of the independent variables (internal and external factors), which have the highest correlation value with the dependent variable dimensions of Y1 (entrepreneurship education) and the dependent variable dimensions of Y2 (entrepreneurial interest) and to determine the dimensions of the dependent variable of Y1 (entrepreneurship education) which has the highest correlation value with the dependent variable dimensions of Y2 (entrepreneurial interest).

**Table 9. The Results of Correlation Matrix Between Dimensions of Independent Variables and Dependent Variables**

Variable	Dimension	Entrepreneurship Education (Y1)			Entrepreneurial Interest (Y2)			
		Y1.1	Y1.2	Y1.3	Y2.2	Y2.5	Y2.6	Y2.8
Internal Factors (X1)	The Soul of Entrepreneurship	0.312	0.272	0.216	0.244	0.206	0.254	0.250
		0.241	0.419	0.213	0.173	0.319	0.224	0.288
	Creativity	0.189	0.260	0.139	0.100	0.209	0.145	0.179
Eksternal Factors (X2)	The natural environment	0.223	0.188	0.178	0.162	0.226	0.206	0.174
		0.112	0.000	0.180	0.055	0.157	0.083	0.313
	Family environment	0.188	0.249	0.094	0.222	-0.051	0.203	0.067

Source: Data processed by the researcher, 2020

**Table 10. The Results of Correlation Matrix Between the Dimensions of Dependent Variables and Dependent Variables**

Variable	Dimension	Entrepreneurship Education (Y1)			
		Y2.2	Y2.5	Y2.6	Y2.8
Entrepreneurship Education (Y1)	Entrepreneurial Characteristics	0.804	0.364	0.879	0.363
		0.200	0.174	0.236	0.182
		0.462	0.238	0.502	0.299

Source: Data processed by the researcher, 2020

**Discussion**

Internal and external factors have a significant positive effect on entrepreneurship education and entrepreneurial interest on students of An Najiyah Vocational School. If internal and external factors are mediated by the entrepreneurship education variable, the effect is significant on entrepreneurial interest. In addition, entrepreneurship education also has a significant positive effect

on entrepreneurial interest. An Najiyah Vocational School students have better personal abilities after getting entrepreneurship education at school. They can also take the opportunity of entrepreneurship from the surrounding environment after getting entrepreneurship education at school. In fact, from internal and external factors, An Najiyah Vocational School students have an entrepreneurial interest but cannot realize it immediately after graduating from vocational schools. In addition, entrepreneurship education that has been learned by An Najiyah Vocational School students can foster students' entrepreneurial interest.

## CONCLUSIONS AND RECOMMENDATIONS

### Conclusion

Based on the results and discussions of previous studies, several conclusions can be made: (1) internal factors have a significant positive effect on entrepreneurship education, with the dimension of the soul of entrepreneurship that have the strongest effect, (2) external factors have a significant positive effect on entrepreneurship education, with the dimension of the family environment that have the strongest effect, (3) internal factors have no significant positive effect on entrepreneurial interest, (4) external factors have no significant positive effect on entrepreneurial interest, (5) entrepreneurship education as a mediator in this study has a significant effect on entrepreneurial interest, (6) internal and external factors together have a significant positive effect on entrepreneurship education, (7) internal factors, external factors, and entrepreneurship education simultaneously have a positive and significant effect on entrepreneurial interest, (8) entrepreneurship education mediates internal factors and external factors on entrepreneurial interest.

### Recommendations

Therefore, the researcher gives the following suggestions: (1) An Najiyah Vocational School teachers are expected to be able to always help to foster the soul of entrepreneurship in students so students can apply in daily life to create ideas/creativity for entrepreneurship in accordance with the wishes of the students themselves. The teachers are expected to always guide and help students to have a good personal attitude and can foster the soul of entrepreneurship among all students. The teachers can always help explain to students how to take the opportunity to entrepreneurship from their family environments such as continuing a family business or those that are already around the environment where students live. The teachers are expected to be able to provide trading practices directly to students so that teachers can see the expertise in individual students to do a matter of entrepreneurial behavior. The teachers can always provide learning about entrepreneurial characteristics to the students so that students can have a good personal attitude in fostering entrepreneurial interest. In addition, An Najiyah Vocational School Tangerang can pay more attention to the environment around students by increasing entrepreneurship education and providing entrepreneurship training, which is expected to foster the student's entrepreneurial interest. (2) The expectation of the author is that further research can explore the variables that affect entrepreneurial interest more closely. The significant effect of entrepreneurship education as a mediator on entrepreneurial interest found in this study opens up the possibility of other effects on entrepreneurship education on other variables.

## REFERENCES

- Afandi, Zaenal. (2019). Strategi Pendidikan Entrepreneurship di Pesantren Al-Mawaddah Kudus. *Bisnis: Jurnal Bisnis dan Manajemen Islam*. Vol. 7, No.1 Juni 2019.
- Aima Havidz. (2015). *Entrepreneurship dan Peluang Usaha*. Jakarta: Inmedia.
- Bagheri, et.al. (2015). Factors Influencing Students Entrepreneurial Intentions: The Critical Roles of Personal Attraction and Perceived Control Over Behavior. *The International Journal of Management Science and Information Technology (IJMSIT)*.
- Budi, & Fabianus Fensi. (2018). Pengaruh Pendidikan Kewirausahaan dalam Menumbuhkan Minat Berwirausaha. *Jurnal Pengabdian dan Kewirausahaan*. Vol.2, No.1. 1-9. 2018.
- Darmawan, & I Gede Ketut. (2016). Pengaruh Norma Subjektif, Personal Attitude, Perceived Behavior Control, dan Aspek Psikologis Terhadap Minat Wirausaha (*Entrepreneurial Intention*). *E-Jurnal Manajemen Unud*, Vol.5, No. 7, 2016: 4660-4689.

- Dessyana, & Benedicta Prihatin Dwi. (2017). The Influence of Innovation and Entrepreneurial Self Efficacy to Digital Startup Success. *International Research Journal of Business Studies*. Vol. X No. 01. 2017.
- Dr. Ghina, & Fanji Ramadhan. (2017). Analisis Karakteristik Kewirausahaan dan Minat Kewirausahaan pada Mahasiswa Fakultas Indutri Kreatif Universitas Telkom Angkatan 2012-2013. *E-Proceeding of Management*: Vol. 4, No. 3 Desember 2017.
- Gustavo Herminio Salati Marcondes de Moraes, et.al. (2018). Effects of Entrepreneurial Characteristics and University Environment on Entrepreneurial Intention. *RAC*, Rio de Janeiro, V.22, N.2, Art.4, PP. 226 248, marco/abril 2018.
- Herdjiono, et.al. (2017). The Factors Affecting Entrepreneurship Intention. *International Journal of Entrepreneurial Knowledge Issue*, 2/2017, Volume 5.
- Hussain, Altaf. (2015). Impact of Entrepreneurial Education on Entrepreneurial Intentions of Pakistani Students. *Journal of Entrepreneurship and Business Innovation*, Vol. 2, No.1.
- Ika R, Dina Affiani, et.al. (2018). Faktor-Faktor yang Mempengaruhi Rendahnya Minat Kewirausahaan Siswa Kelas XI di SMK Texmaco Pernalang. Volume 5 No.1, April 2018.
- Israr, & Mazhar Saleem. (2018). Entrepreneurial Intentions Among University Students in Italy. *Journal of Global Entrepreneurship Research* (2018) 8:20.
- Jairo Adolfo Torres Velasquez, et.al. (2016). Characterization of Entrepreneurial Intention in University Students as From Systematic Entrepreneurship Intention Model: A Case Study. *Cuadernos de Gestion*, Vol. 18 N 2. 2018. PP. 95-114.
- Jodhy, Sendhy Kurniawan, et.al. (2016). Pengaruh Pembelajaran Kewirausahaan dan Karakteristik Wirausaha dalam Meningkatkan Minat Berwirausaha Siswa SMK. *Skripsi, Surakarta: Fakultas Keguruan dan Ilmu Pendidikan Universitas Sebelas Maret, Surakarta*. September 2016.
- Jose Alberto & Urszula kobylińska. (2019). Influence of Personal Variables on Entrepreneurial Intention: A Comparative Study Between Poland and Spain. *Engineering Management in Production and Services*. Volume 11 Issue 1 2019 pages: 68-79.
- Kumar, & Manoti. (2018). A Study on Students Perception for Choosing Entrepreneurship as Career Option. *Pramana Research Journal*. Volume 8, Issue 4, 2018.
- Kurnia, et.al. (2018). Pengaruh Pengetahuan Kewirausahaan dan Efikasi Diri Terhadap Minat Wirausaha. *Jurnal Promosi. Jurnal Pendidikan Ekonomi UM Metro*. Vol.6. No.2 (2018) 48-56.
- Pratiwi, Yenny & I Made Wardana. (2016). Pengaruh Faktor Internal dan Eksternal Terhadap Minat Berwirausaha Mahasiswa Fakultas Ekonomi dan Bisnis Universitas Udayana. *E-Jurnal Manajemen Unud*. Vol.5, No. 8, 2016: 5215-524.
- Putra, et.al. (2018). The Role of Entrepreneurship Education in Cultivating Student's Entrepreneurial Intention: A Theory of Planned Behavior Approach. *International Journal of Entrepreneurship and Business Development*. Volume 1 Number 2, 2018.
- Rio, Iman Luther. (2017). Pengaruh Pengetahuan Kewirausahaan dan Karakteristik Kewirausahaan terhadap Keberhasilan Usaha Kecil Menengah (UKM) di Kelurahan Karang Berombak. *Repositori Institusi USU, Univeristas Sumatera Utara*. <http://repositori.usu.ac.id>.
- Ruswati, Ine. (2018). Faktor Eksternal dan Faktor Internal Terhadap Minat Berwirausaha pada Siswa SMK Yayasan Pendidikan Islam Darussalam Cerme Gresik. *Jurnal Riset Entrepreneurship*. Volume 1 Nomer 2, Agustus 2018, 38-52.
- Sari, & Maryati Rahayu. (2019). Pengaruh Pendidikan Kewirausahaan, Kebutuhan akan Prestasi dan Efikasi Diri Terhadap Intensi Berwirausaha Siswa SMA Muhammadiyah Jakarta. *Ikraith-Ekonomika*. Vol 2 No.1, Maret 2019.
- Siswadi, Yudi. (2013). Analisis Faktor Internal Faktor Eksternal, dan Pembelajaran Kewirausahaan yang Mempengaruhi Minat Mahasiswa dalam Berwirausaha. *Jurnal Manajemen & Bisnis*. Vol 13 No. 01, April 2013.
- Situmeang, & Nurmaidah Ginting. (2016). Pengaruh Konsep Kewirausahaan Terhadap Minat Berwirausaha Siswa SMK Se-Kabupaten Toba Samosir. *AJIE-Asian Journal of Innovation and Entrepreneurship*. Vol.01, No.01, January 2016.
- Sulistiyowati Eny, et.al. (2016). Pengaruh Pendidikan Kewirausahaan di Lingkungan Keluarga, Pembelajaran Kewirausahaan di Sekolah, serta Achievement Motive Terhadap Minat

- Kewirausahaan Siswa SMA. *Jurnal Pendidikan*, Vol.1, No.11, Hal 2226-2229, November 2016.
- Syaifudin, Achmad. (2016). Pengaruh Kepribadian Lingkungan Keluarga dan Pendidikan Kewirausahaan Terhadap Minat Berwirausaha Mahasiswa Program Studi Akuntansi Universitas Negeri Yogyakarta. Hal: 22-24.
- Tiwari, et.al. (2017). An Empirical Analysis of The Factors Affecting Social Entrepreneurship Intentions. *Journal of Global Entrepreneurship Research*, Hal: 7-9. 2017.
- Virginia, & Carlos Atienza-Sahuquillo. (2018). Entrepreneurial Intention Among Engineering Students: The Role of Entrepreneurship Education. *European Research on Management and Business Economics* 24, Hal:53-61. 2018.
- Ward, et.al. (2019). Entrepreneurial Intentions in Students From a Trans National Perspective. *Adm. Sci.* 2019, 9,37: doi: 10.3390/admsci9020037.
- Wahyuningsih Tri, et.al. (2016). Pengaruh Lingkungan Keluarga dan Kepribadian Wirausaha Terhadap Minat Berwirausaha Siswa Kelas XI SMKN Pontianak. *Program Studi S2 Pendidikan Ekonomi Untan Pontianak*. Hal:2.
- Wardani, & Widyanto. (2015). Pengaruh Prestasi Belajar, Lingkungan Keluarga, dan Keaktifan Siswa dalam Business Centre Terhadap Motivasi Berwirausaha Siswa Kelas XI SMK PGRI Tegal. *Kristi Puspa Wardani/ Economic Education Analysis Journal* 4 (2). 2015.
- Widhiandono, et.al. (2016). Pengaruh Faktor Internal, Faktor Eksternal, dan Faktor Pendidikan Terhadap Intensi Kewirausahaan Alumni Mahasiswa. *Prosiding Seminar Nasional Ekonomi dan Bisnis & Call Paper FEB UMSIDA* 2016.
- Wijayanti, & Alit Suryani. (2016). Perbandingan Faktor-Faktor yang Memengaruhi Intensi Berwirausaha Mahasiswa FEB Unud dan Mahasiswa FEB Undiknas. *E-Jurnal Manajemen Unud*. Vol. 5, No. 3, Hal: 1862-1712, 2016.